

# hydra-*wave* Medium Range Ultrasonic Level Transmitter



◆ CAUTION

It is essential that all instructions in this manual be followed precisely to ensure proper operation of the equipment.

## Instruction Manual

---

# NOTICE

The content of this document is the intellectual property of Kistler-Morse Corporation. Any reproduction or translation of this document without the written authorization of a Kistler-Morse corporate officer is prohibited.

---

## SAFETY PRECAUTIONS

### ◆ **User's Responsibility for Safety:**

It is the user's responsibility to select a technology that is appropriate for the application, install it properly, perform tests of the installed system, and maintain all components. The failure to do so could result in property damage or serious injury.

### ◆ **Proper Installation and Handling:**

Because this is an electrically operated device, only properly-trained staff should install and/or repair this product. Use a proper sealant with all installations. *Note: Always install the 2" Viton gasket with the ULT. The G threaded version of the ULT will not seal unless the gasket is installed properly.* Never overtighten the transmitter within the fitting. Always check for leaks prior to system start-up.

### ◆ **Wiring and Electrical:**

A supply voltage of 14-36 VDC is used to power the transmitter. The sensor systems should never exceed a maximum of 36 VDC. Electrical wiring of the sensor should be performed in accordance with all applicable national, state, and local codes.

### ◆ **Temperature and Pressure:**

This sensor is designed for use in application temperatures from -40 °F (-40 °C) to 140 °F (60 °C), and for use at pressures up to 30 psi (2 bar) @ 77°F (25 °C), derated @ 1.667 psi (.113 bar) per degree above 77°F (25 °C).

### ◆ **Material Compatibility:**

The continuous ultrasonic level transmitter is made of two materials. The enclosure is of Polypropylene (PP) and the transducer is made of Polyvinylidene (PVDF). Make sure these materials are chemically compatible with the application liquids and vapors. While the transmitter housing is liquid-resistant when installed properly, it is not designed to be immersed. It should be mounted in such a way that it does not normally come into contact with fluid.

### ◆ **Flammable, Explosive, and Hazardous Applications:**

The level transmitter systems should not be used within flammable or explosive applications.

### ◆ **Make a Fail-Safe System:**

Design a fail-safe system that accommodates the possibility of transmitter or power failure. In critical applications, it is recommended to use redundant backup systems and alarms in addition to the primary system.

# Table of Contents

<b>Introduction</b> .....	<b>i</b>
Description .....	i
About this manual .....	i
Manual Conventions .....	i
Contact Information .....	ii
Technical Service .....	ii
<b>Chapter 1. Pre-Installation of the Medium Range U.L.T.</b> .....	<b>1-1</b>
Programming .....	1-1
Wiring .....	1-2
<b>Chapter 2. Installation of the Medium Range U.L.T.</b> .....	<b>2-1</b>
Mounting .....	2-1
Positioning .....	2-1
Maximum Application Range .....	2-2
Factory Settings .....	2-3
Changing Display Units .....	2-3
Internal Relay .....	2-4
High Level Alarm .....	2-4
Automatic Fill .....	2-4
<b>Appendix A: Product Specifications</b> .....	<b>A-1</b>
<b>Appendix B: Definitions</b> .....	<b>B-1</b>
<b>Appendix C: Troubleshooting</b> .....	<b>C-1</b>



---

# Introduction

*This chapter describes the organization, manual conventions, and provides contact and technical service information.*

---

## Description

An ultrasonic sound wave is pulsed eight times per second from the base of the transducer. The sound wave reflects against the process medium below and returns to the transducer. The microprocessor based electronics measure the time of flight between the sound generation and receipt, and translates this figure into the distance between the transmitter and process medium below.

This manual describes the installation of the Medium Range Ultrasonic Level Transmitter (Medium Range ULT). It includes instructions for installation, product specifications, and troubleshooting notes.

Contact Kistler-Morse at 1-800-426-9010 if you have any questions regarding the installation. Outside the USA and Canada, call 425-486-6600.

---

## About this manual

The chapters are organized in the following way:

Chapter 1:       Pre-Installation of the Medium Range ULT  
Chapter 2:       Installation of the Medium Range ULT

Appendix A through C include specifications, definitions, and troubleshooting.

---

## Manual Conventions

Three kinds of special explanations appear throughout the manual — *Warning, Caution and Note*. The format and significance of each is defined below:

 **WARNING**

Possible danger to people. Injury may result if this information is ignored.

 **CAUTION**

Possible risk to the product. The ULT or other equipment may be damaged if this information is ignored.

 **Note**

Contains additional information about a step or feature critical to the installation or operation of the ULT.

## Contact Information



You may reach Kistler-Morse corporate headquarters at the following:

Mail: Kistler-Morse  
19021 120th Ave NE Suite 101  
Bothell, Washington USA 98011-9505

Telephone: 1-800-426-9010  
(425) 486-6600

Fax: (425) 402-1500

E-mail: [sales@kistlermorse.com](mailto:sales@kistlermorse.com)

Website: <http://www.kistlermorse.com>

---

## Technical Service

A complete, unabridged copy of our product warranty is available upon request from KM. A summary of the warranty, *subject to the terms and conditions listed fully in the warranty*, follows:

KM warrants the equipment to be free from defects in material and workmanship for two years from date of shipment to original user. KM will replace or repair, at our option, any part found to be defective. Buyer must return any part claimed defective to KM, transportation prepaid.

KM maintains a fully trained staff of field service personnel who are capable of providing you with complete product assistance. Our field service staff is based in Bothell, Washington USA (corporate headquarters).

---

### Phone Consultation

Our Customer Service staff provides the following services by telephone, via our regular and toll free number (toll free in U.S.A. and Canada only):

- Technical, application, and troubleshooting assistance
  - Spare parts assistance
  - Warranty (replacement) assistance
- 

### On-Site Consultation

KM's Field Service staff can provide additional services at your request. Contact KM for rate and scheduling information for the following services:

- Technical, application, startup, and troubleshooting assistance on-site
- Training on-site or at our corporate office
- Service calls
- Equipment updates to our latest configuration

General descriptions of some of these standard services follow. Of course, if your service needs vary from those described, we are available to discuss them with you.

---

### Installation, Startup Assistance, and On-Site Training

The system will be powered up and checked for proper electrical operation. Recommendations for the optimal performance of the system will be provided.

---

### Troubleshooting

KM will troubleshoot systems for mechanical, electrical, calibration, and wiring errors. Normal component repairs will be made and wiring errors will be corrected, including replacement of non-repairable printed circuit boards.

---

### Service Calls

KM will perform on-site repair/replacement services.

---

### Return Material Authorization

If a part needs to be sent to the factory for repair, contact KM's corporate office and request a Return Material Authorization (RMA) number. The RMA number identifies the part and the owner and must be included with the part when it is shipped to the factory.

# Chapter 1:

## Pre-Installation of the Medium Range U.L.T.

*This chapter describes the pre-installation programming and wiring for the Medium Range U.L.T. .*

### Programming



*Note: For definitions of the following programming functions, see Appendix B.*

Open the top cap to complete the following instructions.

---

#### EC4:

1. Hold [MENU] key until EC4 appears in display.
2. Release [MENU] key and wait until a value appears. This value is the current measured level value.
3. If this is acceptable, press [SET] to lock the value as the new EC4 set point. If not, press either the [▲] or [▼] keys once and the old setting for the EC4 will appear.
4. From here, use the [▲] or [▼] keys to raise or lower the value to the desired value.
5. Press the [SET] key to enter this value as the new EC4 set point.

---

#### EC20:

1. Hold [MENU] key until EC20 appears in display.
2. Release [MENU] key and wait until a value appears. This value is the current measured level value.
3. If this is acceptable, press [SET] to lock the value as the new EC20 set point. If not, press either the [▲] or [▼] keys once and the old setting for the EC20 will appear.
4. From here, use the [▲] or [▼] keys to raise or lower the value to the desired value.
5. Press the [SET] key to enter this value as the new EC20 set point.

---

#### HSET/LSET:

1. Hold [MENU] key until HSET or LSET appears in the display.
2. Release [MENU] key wait for the display to change to a number.
3. From here, use the [▲] and [▼] keys to raise or lower the value to the desired value.
4. Release all buttons and the value will be entered into memory. The [SET] button does not need to be pressed.
5. Repeat process for the other setting.

---

#### SAF1/SAF2:

1. Hold [MENU] key until SAF1 or SAF2 appears in the display.
2. Release [MENU] key and hold [SET] key to toggle between SAF1 and SAF2.
3. When desired setting is reached, release [SET] key. The last displayed setting will be locked into memory. To change, start again at step 1.

**FAST/SLOW:**

1. Hold [MENU] key until FAST or SLOW appears in the display.
2. Release [MENU] key and hold [SET] key to toggle between FAST and SLOW.
3. When desired setting is reached, release [SET] key. The last displayed setting will be locked into memory. To change, start again at step 1.

**ALIN:**

1. Hold [MENU] key until ALIN appears in the display.
2. Continue to hold [MENU] key until OFF appears in the display.
3. Release [MENU] key and hold [SET] key to toggle from OFF to ON.
4. Release [SET] key. The ULT is now in ALIN mode.
5. To exit ALIN mode, repeat steps 1-4 changing from ON to OFF.

**TANK:**

1. Hold [MENU] key until TANK appears in the display.
2. Continue to hold [MENU] key until a value appears in the display. This value is the current TANK setting.
3. If this is acceptable, press [SET] to lock the value as the TANK setting. If not, use the [▲] or [▼] keys to raise or lower the value to the desired setting.
4. Press the [SET] key to enter this value as the new TANK setting.

**Wiring**

★ *Note: The U.L.T. requires 14-36 VDC power with at least a 200mA supply in order to operate.*

1. Wiring to a *hydra-wave* Continuous Relay Controller:

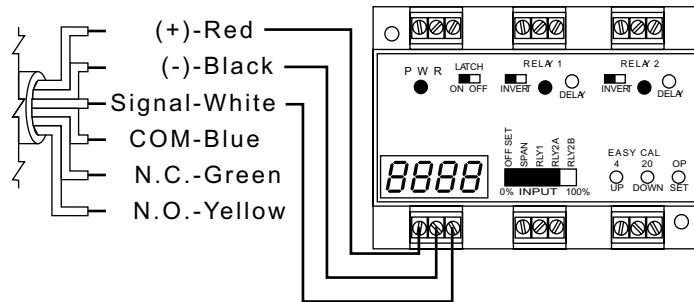

2. Wiring to a Two-Wire Loop Indicator:

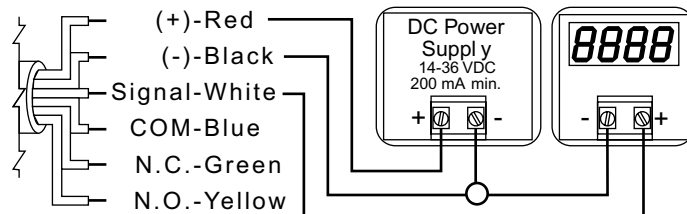

3. Wiring to a PLC:

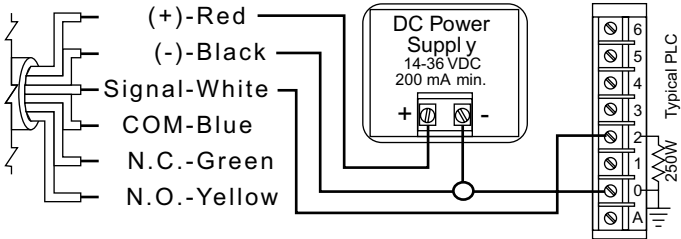

# Chapter 2: Installation of the Medium Range U.L.T.

*This chapter describes the installation procedures including the mounting and the factory settings.*

**Mounting:**  
Mounting the ULT properly is critical to operation. If the ULT is installed such that it is recessed in a fitting or flange, follow the criteria listed below. For an I.D. less than 3", do not recess the ULT more than 1" for best results. *The flange riser height is defined as the distance from the bottom of the transducer to the opening of the tank.*

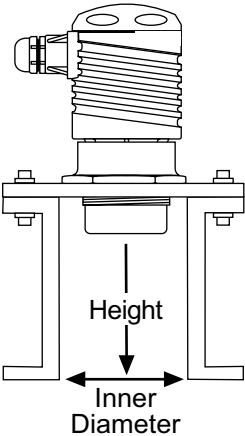

<b>Flange Riser</b>			
<b>I.D.</b>		<b>Height</b>	
<i>(in.)</i>	<i>(cm)</i>	<i>(in.)</i>	<i>(cm)</i>
3	7.6	3	7.6
4	10.2	7	17.8
5	12.7	11	27.9
6	15.2	15	38.1
7	17.8	19	48.3
8	20.3	26	66.0

**Positioning:**

- Top-left: A transducer is mounted on the side of a tank. Text box: "Avoid interference from side of tank."
- Top-right: A transducer is mounted at an angle to the tank's opening. Text box: "Do not install at an angle."
- Bottom-left: A transducer is mounted in a tank with a vertical obstruction (a pipe) in front of it. Text box: "Avoid interference from obstructions in tank."
- Bottom-right: A transducer is mounted in a tank labeled "VACUUM". Text box: "ULT will not operate in a vacuum."

### Maximum Application Range:

The maximum range is 24.5 feet at 110 dB. Yet a number of factors can reduce the overall quality of signal return and shorten the accurate range of the transmitter. To determine the maximum application range of the product, follow the signal return formula against the echo attenuation graph below.

Echo Attenuation Range Graph

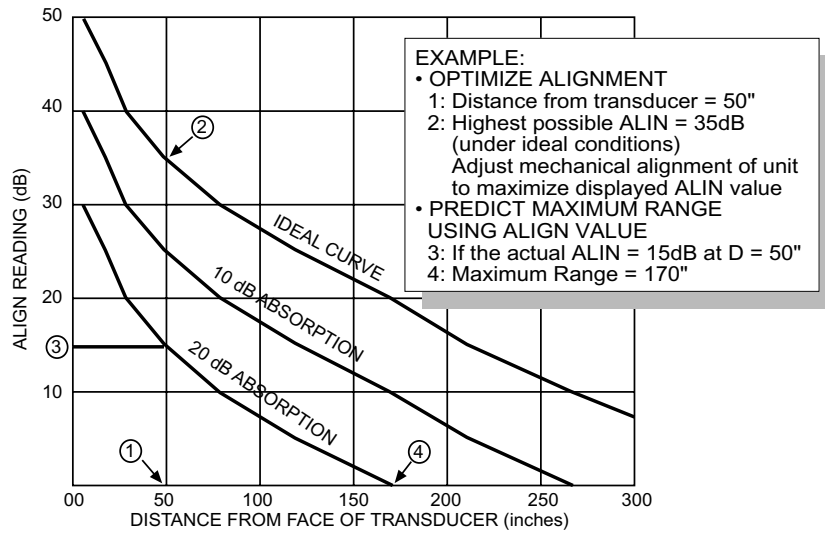

**Factory Settings:**

The ULT is preset at the factory. When powering up the ULT the first time, the factory settings will be active. If at any time you need to return to these settings, remove power from the ULT and wait 10 seconds. Press the [Set] and [Menu] buttons simultaneously while powering up the ULT.

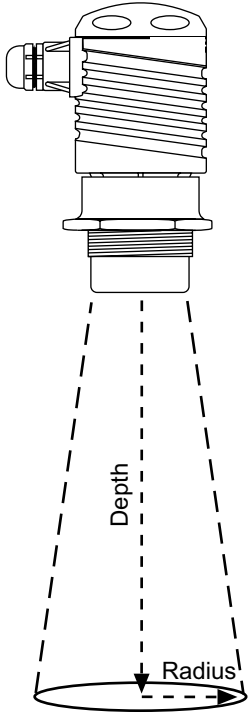

LEVL	INCHES (cm)	SAF1/2	SAF1
EC 4	288" (731.2 cm)	F/S	FAST
EC20	8" (20.3 cm)	ALIN	N/A
RLAY	N/A	OFF/ON	OFF
HSET	5" (12.6 cm)	TANK	N/A
LSET	288" (731.2 cm)	value	288" (731.2 cm)

**Changing Display Units:**

The ULT comes preset to measure in inches. To change the unit to display centimeters, remove power to the unit and wait 10 seconds. Press [▲] and [Set] simultaneously while powering up the ULT. The ULT will now read in centimeters. To return to inches, remove power and wait 10 seconds. Press [▼] and [Set] simultaneously while powering up the ULT.

Depth (feet)	Radius (inches)	Radius (cm)	Depth (feet)	Radius (inches)	Radius (cm)
1	1.2	3.1	21	18.0	45.7
2	2.1	5.2	22	18.8	47.8
3	2.9	7.3	23	19.7	50.0
4	3.7	9.5	24	20.5	52.1
5	4.6	11.6	25	21.4	54.2
6	5.4	13.7			
7	6.2	15.9			
8	7.1	18.0			
9	7.9	20.1			
10	8.8	22.3			
11	9.6	24.4			
12	10.4	26.5			
13	11.3	28.7			
14	12.1	30.8			
15	13.0	32.9			
16	13.8	35.1			
17	14.6	37.2			
18	15.5	39.3			
19	16.3	41.3			
20	17.2	43.6			

**Internal Relay:**

The ULT contains a 250 VAC, 10A, 1/2 Hp internal relay. The relay is actuated by the HSET and LSET settings. While this manual offers some examples and suggestions to help explain the operation of the relay, such examples are for information only and are not intended as a complete guide to installing any specific system.

**High Level Alarm:**

The goal is to make sure the liquid does not rise above a certain point. If it does, an alarm sounds alerting the operator to a high level condition. Wire the hot lead of the alarm to the Green NC relay wire. Also make sure the HSET and LSET settings are programmed correctly. Typically the values are set at the same distance away from the ULT.

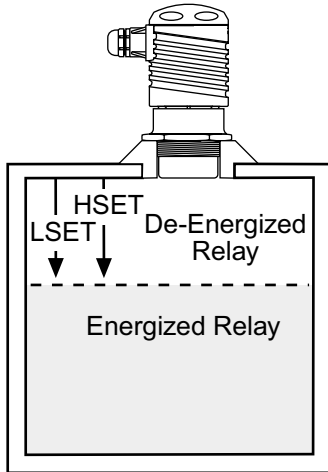

In the normal operation state, the ULT's relay will remain energized, keeping the alarm circuit open. When the alarm level has been reached, the relay de-energizes and activates the alarm. To change to a low level alarm, re-wire the alarm from the Green NC wire to the Yellow NO wire.

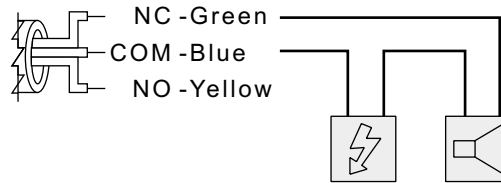

**Automatic Fill:**

The goal is to fill the tank. A valve is opened (energized) when a low level is reached and closed (de-energized) when a high level is reached. Wire the hot lead of the valve to the Yellow NO relay wire. Make sure the HSET and LSET settings are programmed correctly. Typically the values are set with the HSET as the valve closes and the LSET as the valve opens. A pump or solenoid can be substituted for the exact same operation.

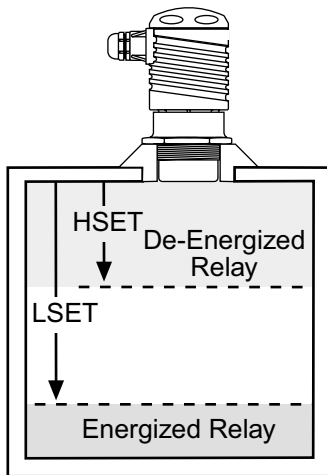

When the low level is reached, the system will start to fill the tank. The tank will continue to fill until the level reaches the high point. The system stops filling when the low level is reached again. To change to an automatic empty application, re-wire the system from the Yellow NO wire to the Green NC wire.

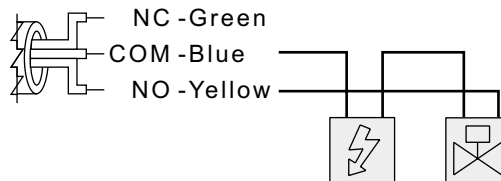

# Appendix A: Product Specifications

<b>Accuracy:</b>	Range:	0.5 to 24.5 feet (15 cm to 7.4 m)	<b>Physical:</b>	Enclosure rating:	NEMA 4X (IP65)
	Accuracy:	± 0.25% of span (air)		Enclosure material:	Polypropylene, U.L. 94VO
	Resolution:	0.125" (3 mm)		Transducer material:	Polyvinylidene Fluoride
<b>Rate:</b>	Frequency:	50 kHz		Mounting threads:	2" NPT (2" G)
	Pulse rate:	8 pulses per second		Mounting gasket:	Viton (2") metric only
<b>Beam:</b>	Beam width:	8° conical	<b>CE compliance:</b>	Conduit connection:	1/2" NPT
	Blocking distance:	0.5' (15 cm) minimum			EN 50082-2 immunity
<b>Display:</b>	Type:	4 segment LED			EN 55011 emission
	Display units:	Inches (cm)			EN 61010-1 safety
<b>Memory:</b>		Non-volatile			
<b>Electrical:</b>	Supply voltage:	14-36 VDC			
	Consumption:	200 mA			
	Current flow:	Source			
	Signal output:	4-20 mA, 14-36 VDC			
	Signal invert:	4-20 mA / 20-4 mA			
	Signal averaging:	Fast / slow			
	Calibration:	Push button			
<b>Relay:</b>	Relay type:	(1) SPDT			
	Relay output:	250 VAC, 10A, 1/2 hp			
	Relay mode:	Selectable, NO or NC			
	Relay indication:	ON / OFF status			
	Contact resistance:	30 milliohm			
<b>Fail-safe diagnostics:</b>		Relay reverts to safe position			
<b>Temperature:</b>	Temperature rating:	F: -40° to 140° C: -40° to 60°			
	Temp. compensation:	Automatic over entire range			
<b>Pressure:</b>	Pressure rating:	30 psi (2 bar) @ 25 °C (77°F), derated @ 1.667 psi (.113 bar) per degree above 25 °C (77°F).			

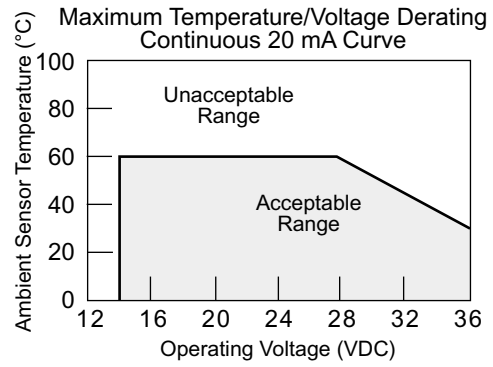
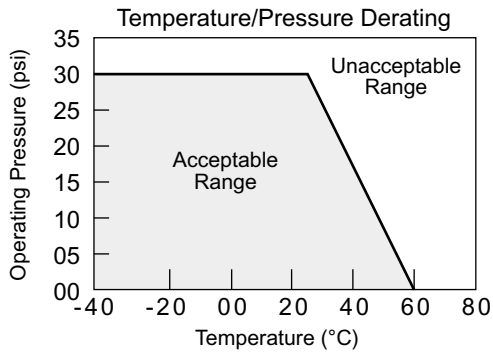
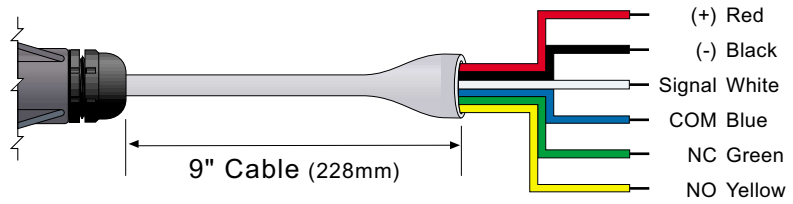
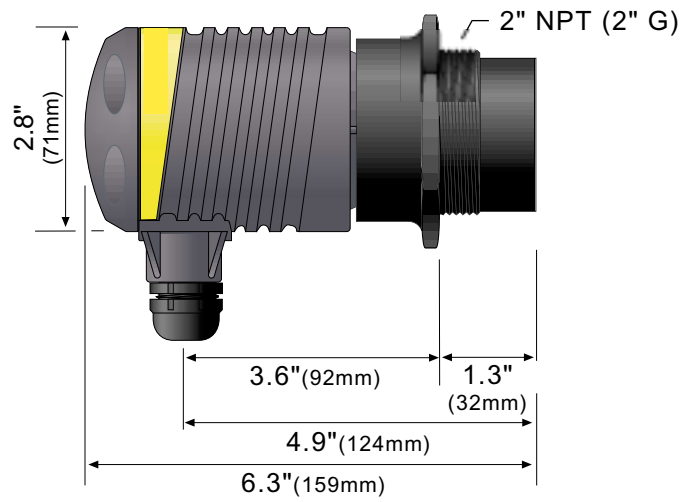

# Appendix B: Definitions

*This section contains definitions for programming functions.*

## EC4

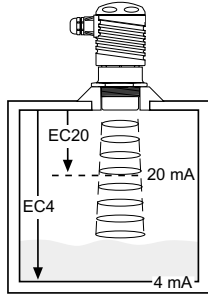

The 4 mA setting for the Med. Range ULT. The EC4 is the distance from the bottom of the ULT to the 4 mA set point. This setting is measured in either inches or centimeters on the display. The EC4 setting is typically greater than the EC20 setting.

## EC20

The 20 mA setting for the Med. Range ULT. The EC20 is the distance from the bottom of the ULT to the 20 mA set point. This setting is measured in either inches or centimeters on the display.

## RLAY

Indicator for the next two modes. The 10A relay is latched between the HSET and LSET points.

## HSET & LSET

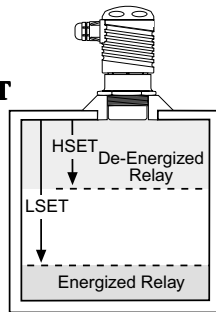

Sets the high point and low point for relay activation. Relay will energize when display value is greater than the LSET value. Relay will de-energize when display value is less than the HSET value. The HSET value is always less than the LSET value. To activate the relay from a single point, set HSET and LSET to the same value.

## SAF1/SAF2

The 10A relay inside the ULT can be used in a fail-safe design of your system. When [SAF1] is set, the relay will de-energize when the acoustic return signal is LOST. When [SAF2] is set, the relay will energize when the acoustic return signal is LOST. Response times will vary according to the setting of the ULT ([FAST] or [SLOW] modes).

## FAST/SLOW

FAST and SLOW sets the reaction time for the SAF1/SAF2 setting. [FAST] is the typical setting for the ULT to operate. The time for the RELAY to default is 30 seconds for the [FAST] mode and 2.5 minutes for the [SLOW] mode.

## ALIN

Indicates that the unit is in the Alignment mode. Display will show the return signal strength in dB's. Used as an indicator for mechanical alignment of the ULT and/or signal attenuation. Typical readings range between 2 and 60 dB's. For optimum alignment, first energize the unit and receive a valid return signal. Then select the ALIN mode and adjust the ULT until the value is maximized.

## ON/OFF

Actual setting for ALIN mode. The ALIN mode must be turned [OFF] when alignment is completed. This mode will not automatically default back to [LEVL].

## TANK

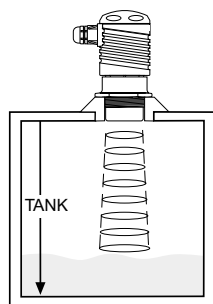

Used as an indication for [TANK] or maximum range. The TANK sets the maximum tank height and will filter out all acoustic signal returns greater than this value.

## (value)

Actual TANK setting. The maximum distance is 288.0 inches.

# Appendix C: Troubleshooting

*This section includes troubleshooting notes for the Medium Range ULT.*

## Lost Signal:

A reading of LOST in the display indicates the transmitter is not receiving a valid return signal. If LOST appears, please check the following troubleshooting items:

1. Beam cone interferences such as the side wall, ladders, seams, rungs or pipes within the ULT's beam cone.
2. Proper installation such that the ULT is installed level and free from interference from the installation fitting.
3. Sufficient power being supplied to the ULT. It requires 14-36 VDC power with a minimum supply of 200 mA.
4. Proper programming of the TANK function. The TANK function is often set as the distance from the bottom of the tank to the bottom of the transmitter.
5. Make sure that the transmitter is not installed at an angle. Even a 5 degree offset can reduce the signal return strength greatly.

## Current is always 4mA or 20 mA:

If the output of the ULT is always reading 4mA or 20 mA, check the input values for the ULT. The display reads to the 1/10 of an inch. A display of 1234 is 123.4" and not 1234".

## Other Hints:

When checking the EC4 and EC20 values, the first value which appears after EC4 or EC20 is the current distance from the bottom of the transmitter to the surface of the liquid. Pressing either the [▲] or [▼] buttons will then show the actual value in memory.

## General:

The ULT itself requires no periodic maintenance except cleaning as required. It is the responsibility of the user to determine the appropriate maintenance schedule, based on the specific characteristics of the application liquids.

## Cleaning Procedure:

1. Power: Make sure that all power to the ULT, controller and/or power supply is completely disconnected.
2. ULT Removal: In all through-wall installations, make sure that the tank is drained well below the ULT prior to removal. Carefully, remove the ULT from the installation.
3. Cleaning the ULT: Use a soft bristle brush and mild detergent, and carefully wash the ULT. Do not use harsh abrasives such as steel wool or sandpaper, which might damage the surface sensor. Do not use incompatible solvents which may damage the Polypropylene or PVDF body.